

DHP0⁰ - 6⁰ Horizontal Passenger - Travelator Layout Drawing

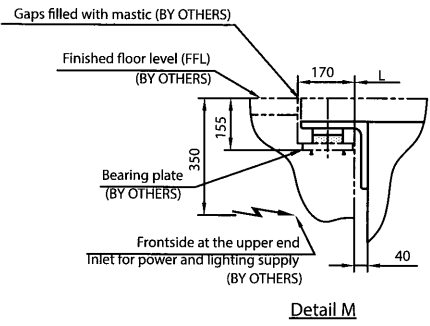
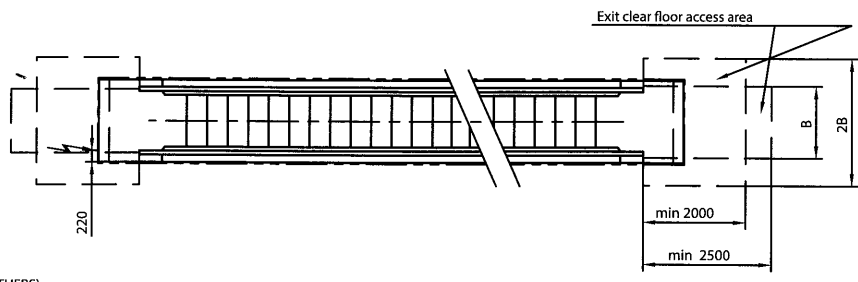
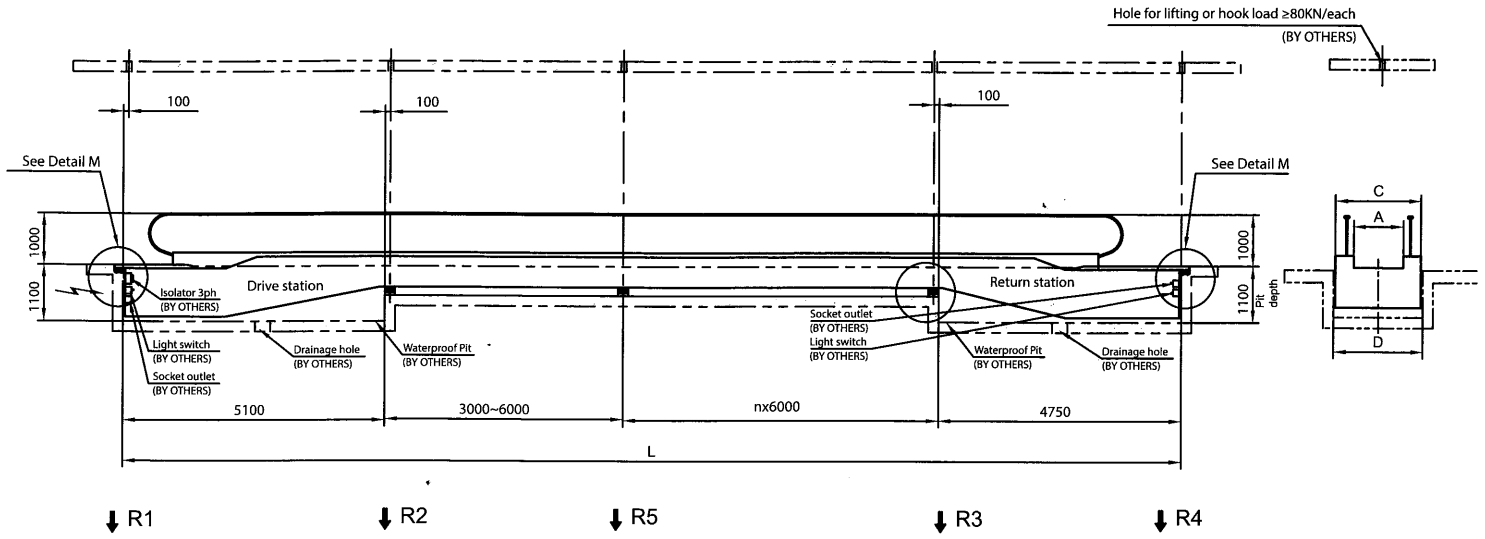

Type	A	B	C	D	Speed
DHP - 800	800	1350	1400	1460	V=0.5m/s
DHP - 1000	1000	1550	1600	1660	

- Remarks:
1. There should be no water in the pit, and the surface of the pit should be smooth and flat.
 2. The building support at both end of travelator should keep in level.
 3. If the two travelators are put in parallel, the gap between the two travelators should not less than 10mm.
 4. All dimension in mm.